

# Product Datasheet TRIO110

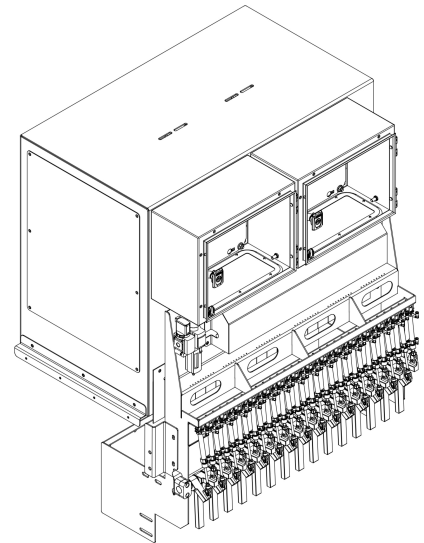

## AI-POWERED OPTICAL SORTING FOR POTATOES & ONIONS

The Karevo TRIO110 is an AI-powered optical sorting system with a 110 cm working width, developed specifically for agricultural enterprises and direct marketers. The system uses two robust industrial cameras and state-of-the-art image processing to deliver pixel-accurate defect detection in real time with over 15 images per potato. Thanks to edge computing, the AI runs locally – no internet required for operation. The system sorts unwashed table potatoes, seed potatoes, and onions at a throughput of up to 10 tonnes per hour – gentle, precise, and reliable.



### HIGHLIGHTS

- ✓ Specially developed for family farms and direct marketers
- ✓ Sorts both potatoes and onions – yellow and red varieties
- ✓ Higher detection accuracy than manual sorting (~95%)
- ✓ Works with unwashed potatoes
- ✓ 110 cm working width – up to 10 tonnes per hour
- ✓ Two industrial cameras with over 15 images per potato
- ✓ Edge computing – no internet required for operation

### Technical Performance

- Complete pixel-accurate quality analysis in real time
- Adaptable to different potato varieties, onions, and operating conditions
- Reliable foreign body detection (stones, clods)
- Simple operation via touchscreen with sorting statistics
- Optical system can be deactivated – flexible deployment

### Economic Benefits

- Savings in working time and labor costs
- Increased flexibility during labor-intensive phases
- Simplified personnel planning
- Consistently high sorting quality over long working periods

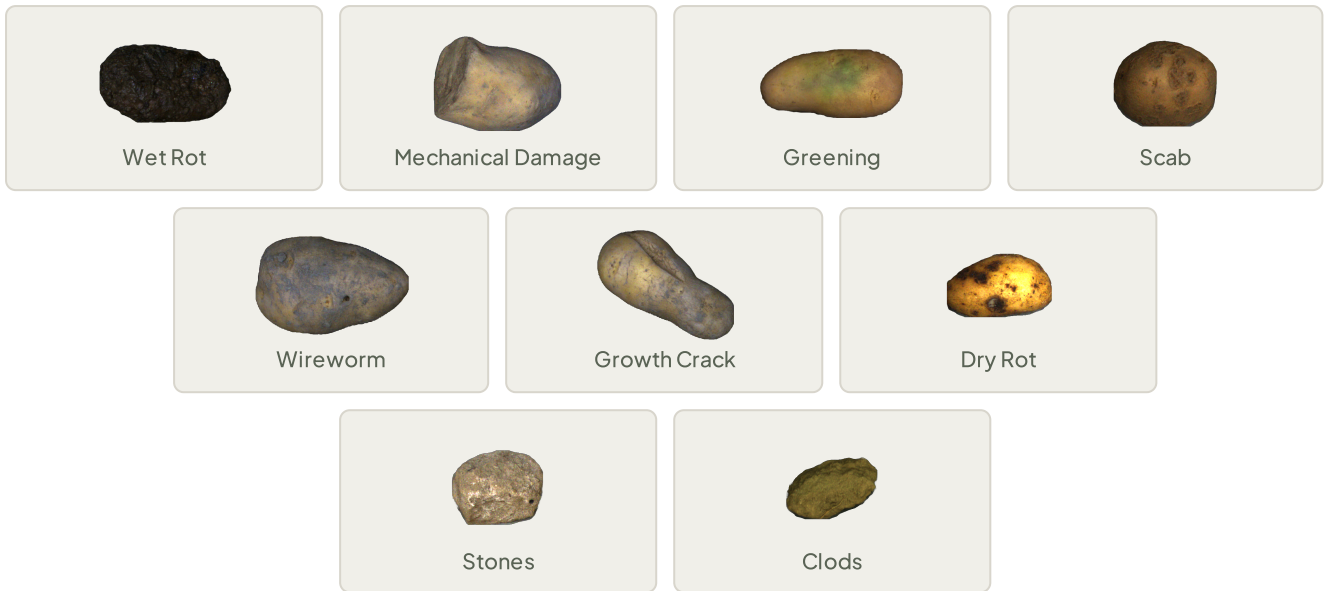

## AVAILABLE CONFIGURATIONS

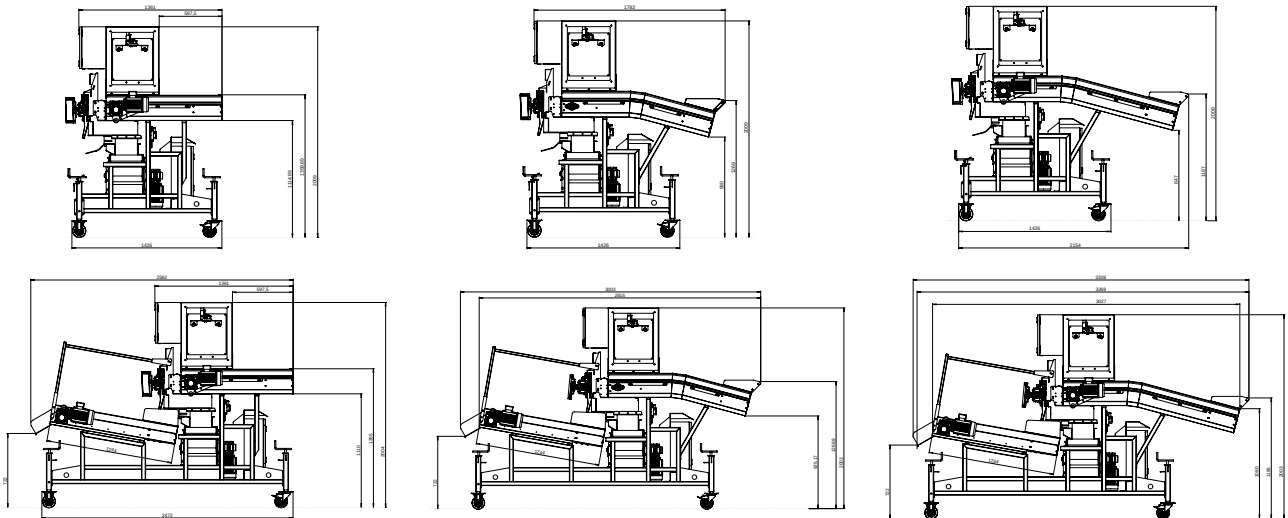

## TECHNICAL SPECIFICATIONS

Property	Value
Sorting Capacity	Up to 10 tonnes per hour
Detection Accuracy	≈ 95%
Detected Defects	Greening, rot, mechanical damage, wireworm, growth cracks, scab – incl. defect size, stones & clods
Application Area	Unwashed table potatoes, seed potatoes, yellow and red onions
Ejection Mechanism	Pneumatic fingers
Working Width	1100 mm (110 cm)
Power Supply	400 V, 50 Hz, total power requirement approx. 1.5 kW
Compressed Air	Oil-free compressed air, 6 bar